

# How to Read With Expression

Change your pitch.

Vary your speed fast/slow.

Use your eyes.

Talk like the character.

Vary your volume: loud/soft.

Read with confidence.

Stress important words.

Vary your emotions: happy/sad, excited/bored, calm/nervous.

Use punctuation clues.

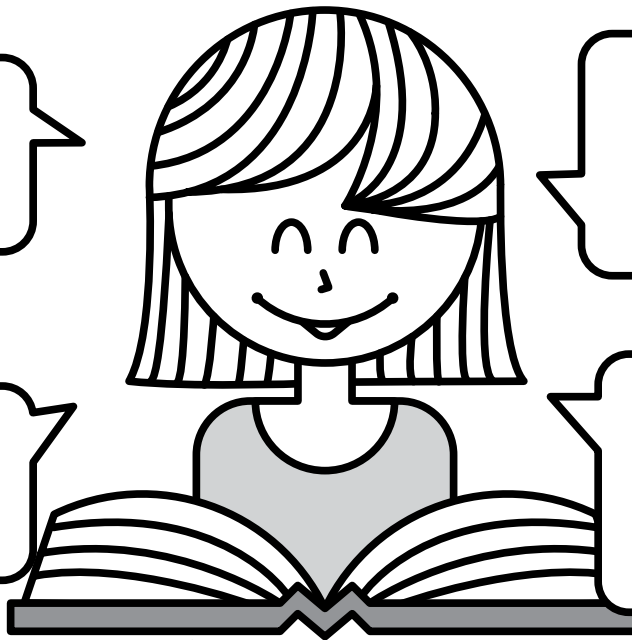

Read  
With  
**Expression**

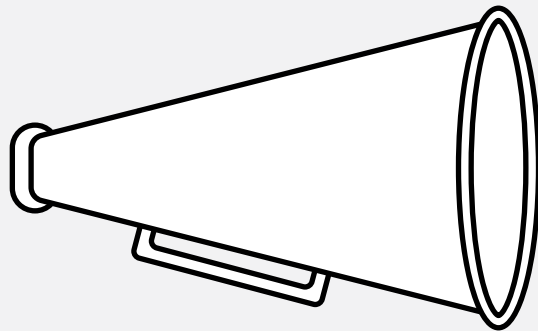

**Watch your volume and tone.  
Be confident and natural!**

Read  
With

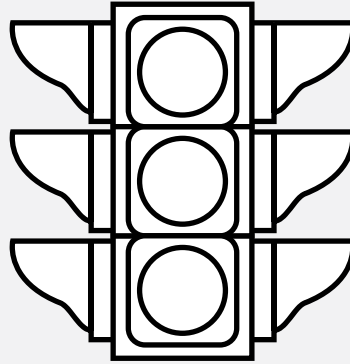

**Automatic  
Word  
Recognition**

**Read effortlessly  
and at a good pace!**

Read  
With

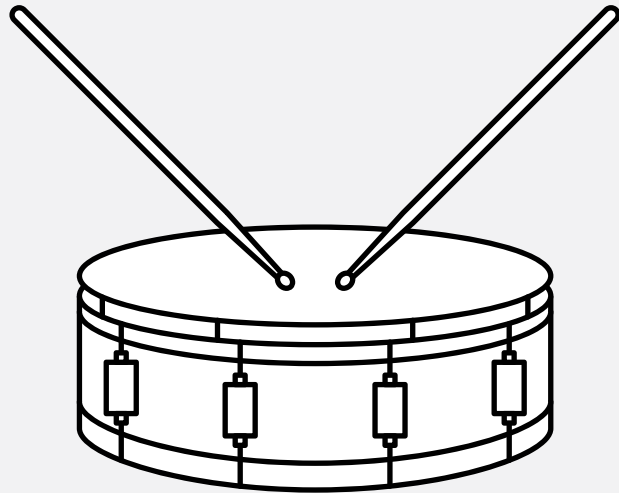

**Rhythm  
and  
Phrasing**

**Go phrase by phrase. Pay  
attention to punctuation.  
Be easy on the ear!**

Read  
With   
**Smoothness**

**Sound smooth, go with the  
flow, and fix mistakes!**

# How to Read With Expression

Change your pitch.

Vary your speed fast/slow.

Use your eyes.

Talk like the character.

Vary your volume: loud/soft.

Read with confidence.

Stress important words.

Vary your emotions: happy/sad, excited/bored, calm/nervous.

Use punctuation clues.

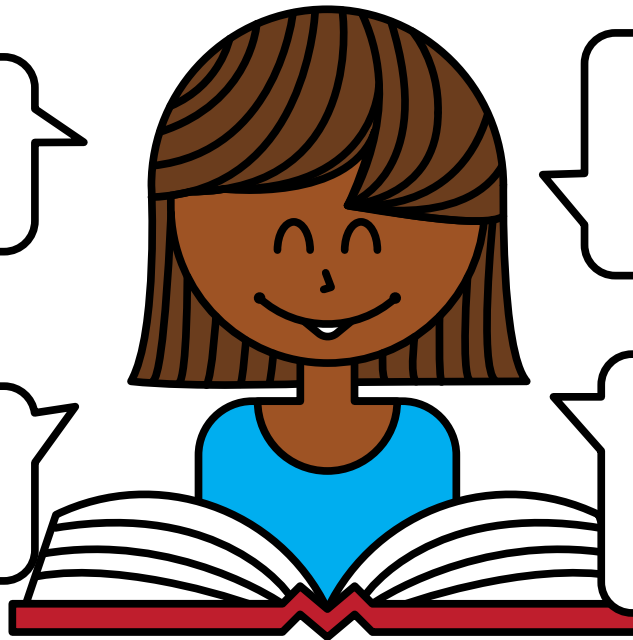

# Read With **Expression**

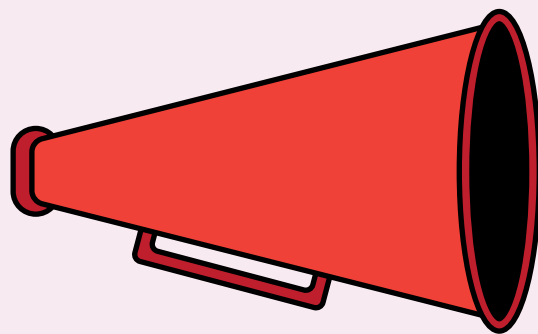

**Watch your volume and tone.  
Be confident and natural!**

Read  
With

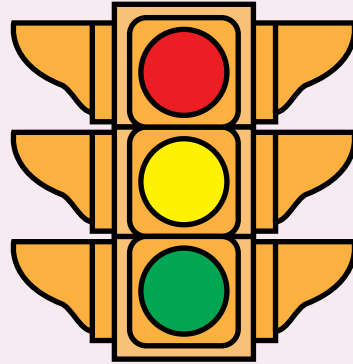

**Automatic  
Word  
Recognition**

**Read effortlessly  
and at a good pace!**



# Read With **Rhythm and Phrasing**

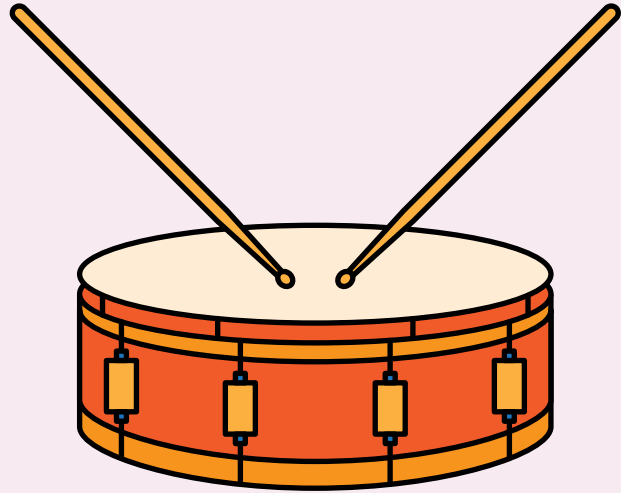

**Go phrase by phrase. Pay  
attention to punctuation.  
Be easy on the ear!**

Read  
With   
**Smoothness**

**Sound smooth, go with the  
flow, and fix mistakes!**